



PermEntry Basement Entrances Selection & Installation Chart

Pre-Installation Requirements:

1. Provide truck access to within 10' of the foundation.
2. Foundation footing and opening should be level, plumb and square.
3. 40" maximum width for foundation opening.
4. Ensure proper drainage by installing a footing drain below the unit. Lack of drains may cause leaking.
5. Leave a minimum work area as shown on the left.
6. The floor slab should be poured even with the outside of the foundation wall. Sizes S through D need a 2" drop from finished floor to footing and sizes E and F need a 4" drop.
7. Keep foundation coating back 12" from each side of opening. The unit needs to be sealed against uncoated concrete.
8. For precast **Superior Walls** you will need to provide a concrete footing measuring 12" w x 60" l x 8" h.

How To Measure:

1. Measure from the top of the foundation footing to the finished grade.
2. Refer to the table below to select a size which is at least 2" higher than finished grade.
3. Add the stair height (HS) to the door height (HD) to get an overall height. If this is shorter than your foundation then you will need a wood or concrete header over the door opening in the wall. If this is higher than your foundation then you will need to adjust your siding around it and your wall should be flush with the foundation for a tight fit.

Post-Installation Requirements:

1. Properly backfill around the unit with compacted clean fill or stone. Never use construction debris or backfill higher than 2" from the top.
2. Slope grade away from the unit in all directions.
3. Avoid locating down spouts or other discharges near the unit.
4. An insulated door in the foundation is recommended as the Bilco door is not air-tight.
5. A finish coat of alkyd metal enamel must be applied to all metal surfaces inside and out. The door comes with just a primer. Do not use an oil base wood paint.
6. Exterior locks are available.

*Widths and lengths given are of the concrete stairs. The Bilco doors will be 1/2" to 4-1/2" narrower and 2" shorter.

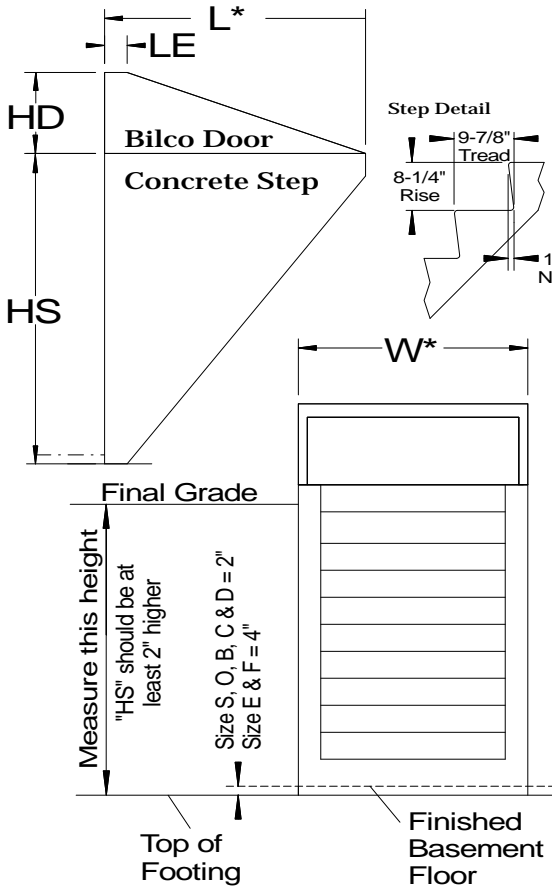
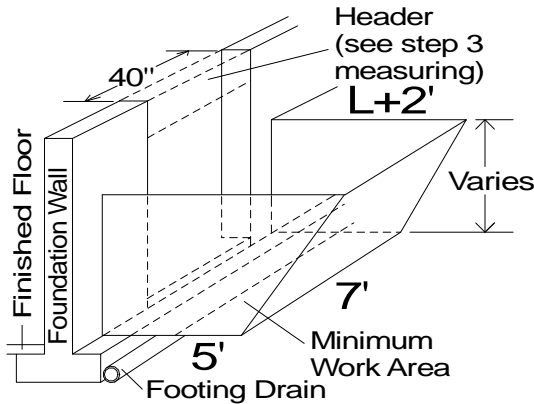

TYPE	STAIR HEIGHT HS	WIDTH W*	LENGTH L*	DOOR HEIGHT HD	EXTENSION LE
S	43"	51-1/2"	45"	52"	0"
O	60"	51-1/2"	60"	30"	0"
B	68"	55-1/2"	66"	22"	0"
C	76"	55-1/2"	74"	19-1/2"	0"
D	84"	55-1/2"	86"	22"	12"
E	94-3/4"	58"	95-3/8"	22"	18"
F	103"	58"	104"	22"	30"